

Owner's Instruction and Operation Manual



Model Number:
6041 Multi-Fuel Stove



Report Number: F20-573

Tested Per EPA Method ASTM E2779-10
and ASTM E1509-2022

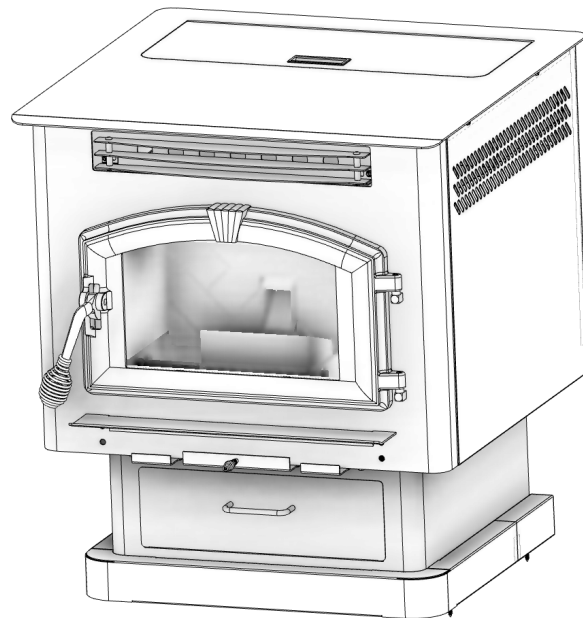

* All Pictures In This Manual Are For Illustrative Purposes Only. Actual Product May Vary.

854082D-3004N

Save These Instructions In A Safe Place For Future Reference.



SAFETY NOTICE: If this heater is not properly installed, a house fire may result. For your safety, follow the installation instructions. Never use make-shift compromises during the installation of this heater. Contact local building or fire officials about permits, restrictions and installation requirements in your area. **NEVER OPERATE THIS PRODUCT WHILE UNATTENDED.**



CAUTION! Please read this entire manual before you install or use your new room heater. Failure to follow instructions may result in property damage, bodily injury, or even death. Improper Installation Will Void Your Warranty!

U.S. Environmental Protection Agency

Certified to comply with 2020 particulate emissions standards.



CALIFORNIA PROPOSITION 65 WARNING:

This product can expose you to chemicals including carbon monoxide, which is known to the State of California to cause cancer, birth defects, and/or other reproductive harm. For more information, go to www.P65warnings.ca.gov

THIS MANUAL IS SUBJECT TO CHANGE WITHOUT NOTICE.

This manual describes the installation and operation of the United States Stove Company 6041 multi-fuel heater. This heater meets the 2020 U.S. Environmental Protection Agency’s pellet fuel emission limits for wood heaters sold after May 15, 2020. Under specific test conditions this heater has been shown to deliver heat at rates ranging from 7,540 to 21,811 Btu/hr output. This heater achieved a particulate emissions rate of 1.3 g/hr and 58% efficiency when tested to method ASTM E 2779-10. This heater is approved for dual fuel use with dried corn with emissions results of 1.4 g/hr.

Heating Specifications		
Heating Capacity	1,000-2,000 Sq. Ft	* Pellet size may affect the actual rate of fuel feed, burn times, and hopper capacity. Fuel feed rates may vary by as much as 20%. Use PFI listed fuel for best results.
Hopper Capacity *	*up to 60 Lbs.	
Flue Size	3” or 4”	
Floor to center of rear vent	12.17” (310 mm)	
Electrical Specifications		
Electrical Rating	120 Volts, 60 HZ, 15 Amps	
Dimensions		
Overall: Height x Width x Depth	29” x 24” x 28” (737 mm x 610 mm x 711 mm)	
Floor To Exhaust Pipe Center	12.17” (310 mm)	
Floor To Fresh Air Intake Center	11.85” (301 mm)	

WARNING:

IT IS AGAINST FEDERAL REGULATIONS TO OPERATE THIS WOOD HEATER IN A MANNER INCONSISTENT WITH THE OPERATING INSTRUCTIONS IN THE OWNER’S MANUAL.



Note: Register your product by using your smart phone with the QR code. Save your receipts with your records for any warranty claims.

You can also register your product online at www.usstove.com/support/product-registration / OR by downloading the US Stove Company app available for iOS and Android.

For Customer Service, please call:
1-800-750-2723 Ext 5050 or;
Text to 423-301-5624 or;
Email us at:
customerservice@usstove.com

INSTALLATION CHECKLIST



Your Wood Stove should be installed by a qualified installer only. An NFI qualified Installer can be found at www.nficertified.org/public/find-an-nfi-pro/

CUSTOMER SERVICE

1-800-750-2723 ext 5050
Text to 423-301-5624
Email to: Customerservice@usstove.com

COMMISSIONING CHECKLIST

This checklist is to be completed in full by the qualified person who installs this unit. Keep this page for future reference. Failure to install and commission according to the manufacturer's instructions and complete this checklist will invalidate the warranty.

Please Print

Customer Name:	Telephone Number:
Address:	
Model:	
Serial Number:	
Installation Company Name:	Phone Number:
Installation Technician's Name:	License Number:

DESCRIPTION OF WORK

Location of installed appliance: _____

Venting System: New Venting System Yes No If yes, Brand _____

If no, Date of inspection of existing venting system: _____

COMMISSIONING

- Confirm Hearth Pad Installation as per Installation Instructions.....
- Confirm proper placement of internal parts.....
- Check soundness of door gasket and door seals
- Confirm clearances to combustibles as per installation instructions in this manual
- Check the operations of the air controls.....
- Confirm the venting system is secure and sealed
- Confirm the stove starts and operates properly
- Check to ensure a CO alarm is installed as per local building codes and is functional
- Explain the safe operation, proper fuel usage, cleaning, and routine maintenance requirements.....

Declaration of Completion: As the qualified person responsible for the work described above, I confirm that the appliance as associated work has been installed as per manufacturer's instructions and following any applicable building and installation codes.

Signed: _____ Print Name: _____ Date: _____

Home Owner: RETAIN THIS INFORMATION FOR FUTURE REFERENCE

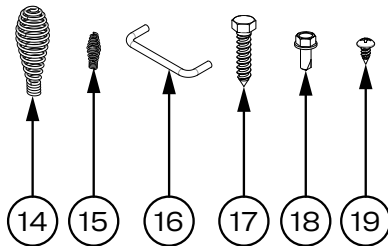
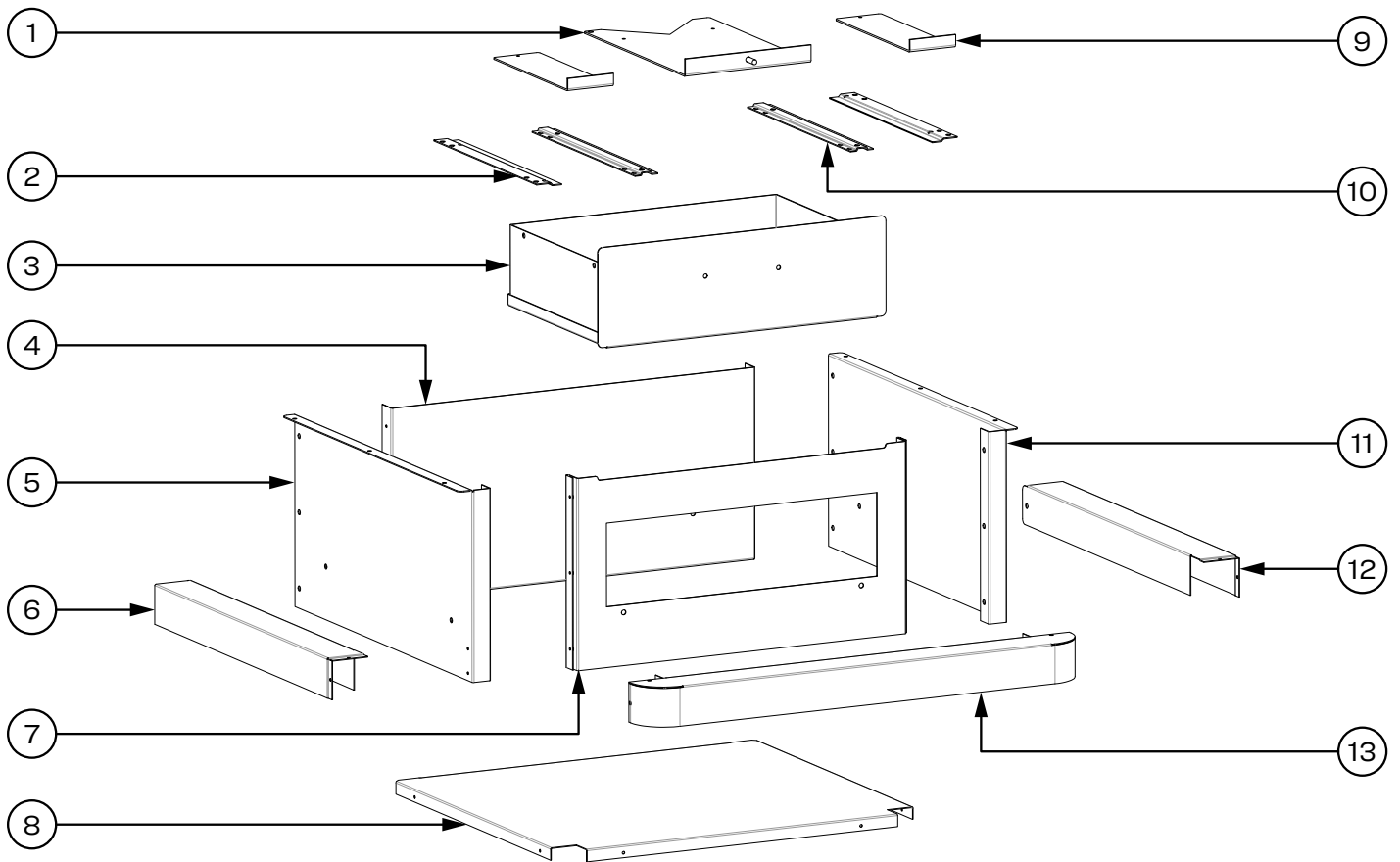

KEY	DESCRIPTION	QTY
1	Damper Weldment	1
2	Clean-out Guide	2
3	Ash Pan Weldment	1
4	Back Panel	1
5	Left Side Panel	1
6	Left Side Trim	1
7	Front	1
8	Shelf	1
9	Lower Ash Clean-out	2
10	Clean-out/Damper Guide	2
11	Right Side Panel	1
12	Right Side Trim	1
13	Front Trim	1
14	Large Spring Handle	1
15	Small Spring Handle - Brushed Nickel	1
16	Brushed Nickel Handle	1
17	1/4 x 1 Lag Screw	1
18	# 10 Screw	22
19	# 8 Self Tapping Screw	16

Remove the included parts/hardware from the stove. Identify parts and part quantities prior to assembly. Assembly of the pedestal to the stove requires 2 or more people.

DOOR HANDLE INSTALLATION

Twist the large spring handle onto the handle rod.

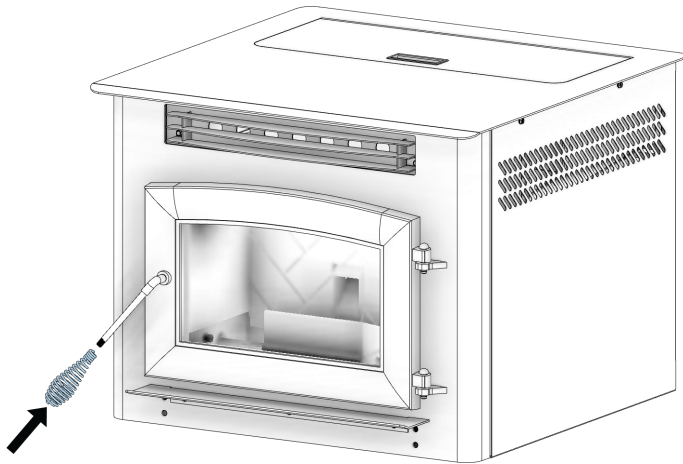

ASH PAN HANDLE

Use the two (2) provided screws to secure the brushed nickel handle to the ash pan.

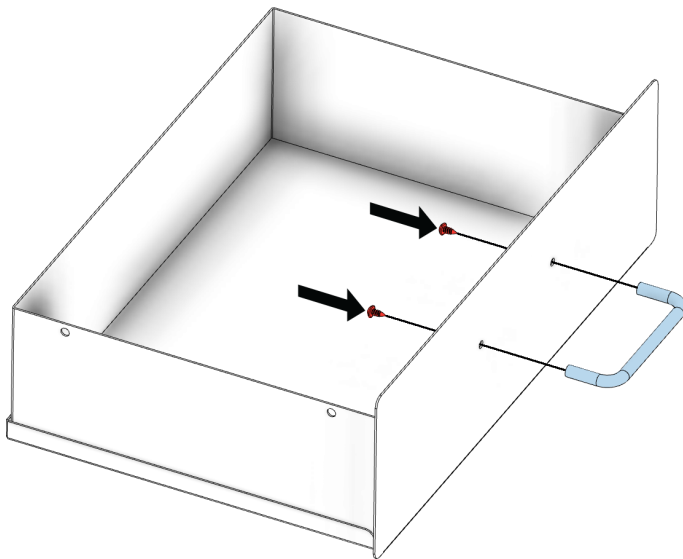

PEDESTAL

NOTE: The stove is heavy and requires 2 or more people to move.

Slide the left and right side panels into the front panel. Use the six (6) provided #10 screws to secure the side panels to the front panel.

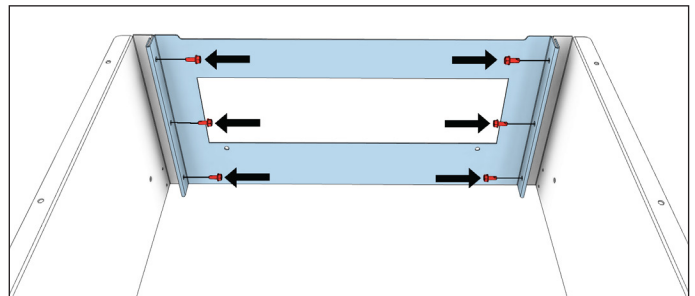
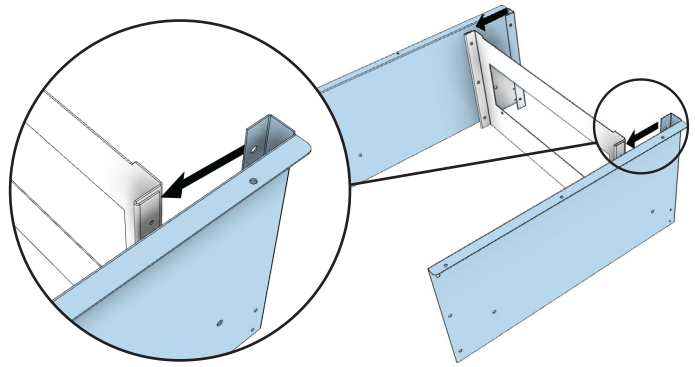

Use the four (4) provided #10 screws to secure the back panel to the left and right panels.

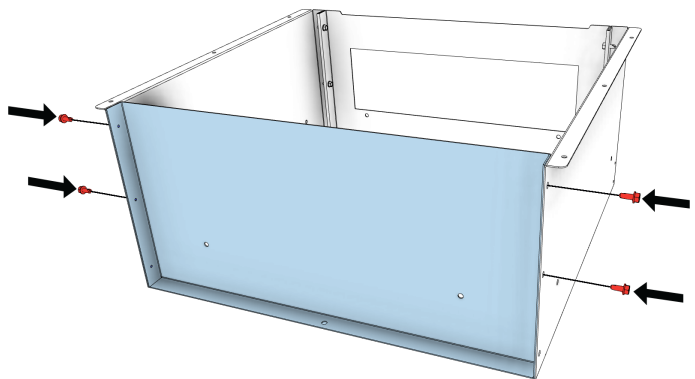

Use the two (2) provided #10 screws to secure the left side trim and right side trim to the side panels of the pedestal assembly.

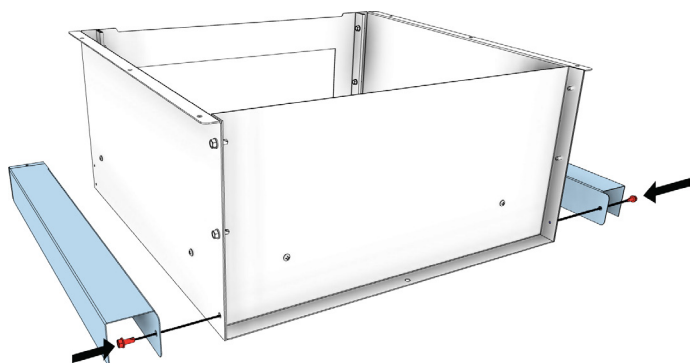

ASSEMBLY

Use the four (4) provided #8 screws to secure the front trim to the left and right side trims.

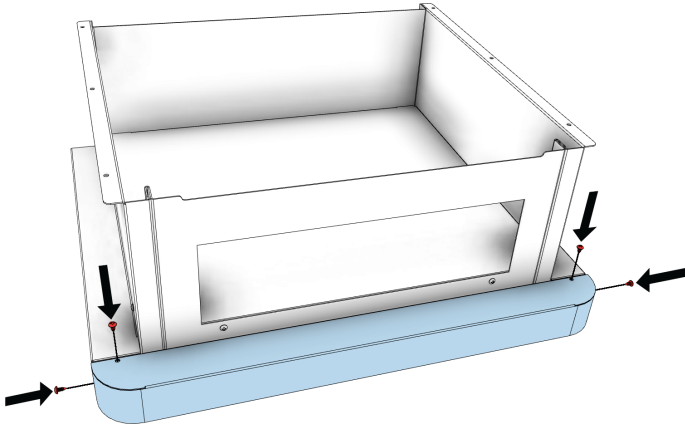

Use the four (4) provided # 10 screws to secure the front trim to the pedestal assembly.

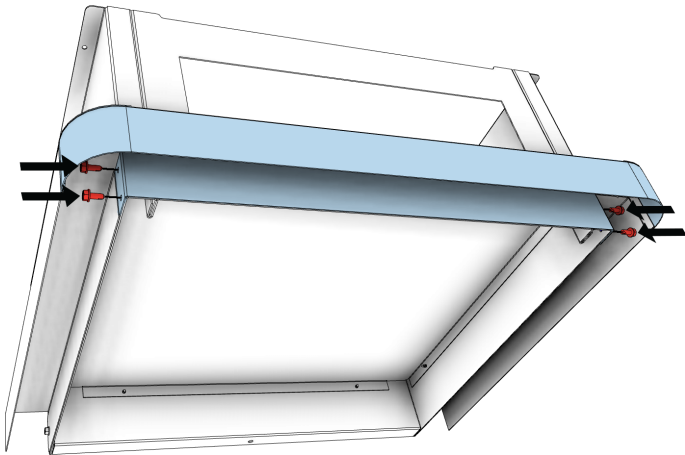

Use the four (4) provided # 10 screws to attach the two lower ash clean-out guides to the bottom of the unit.

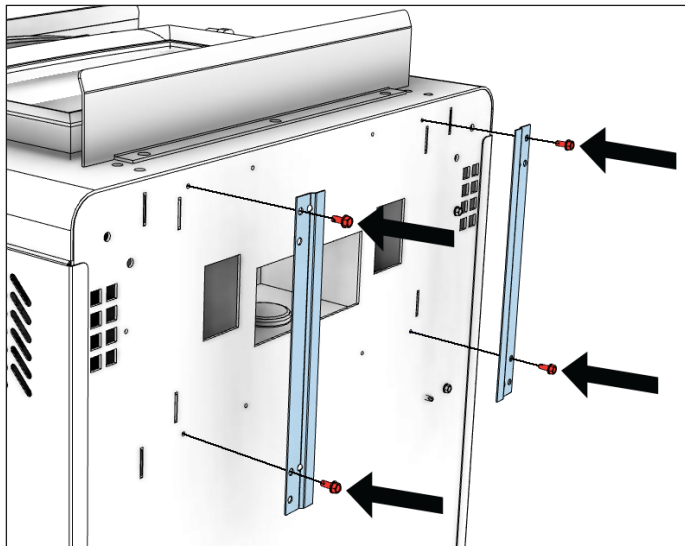

Use the four (4) provided # 10 screws to attach the two clean-out/damper guides to the bottom of the unit.

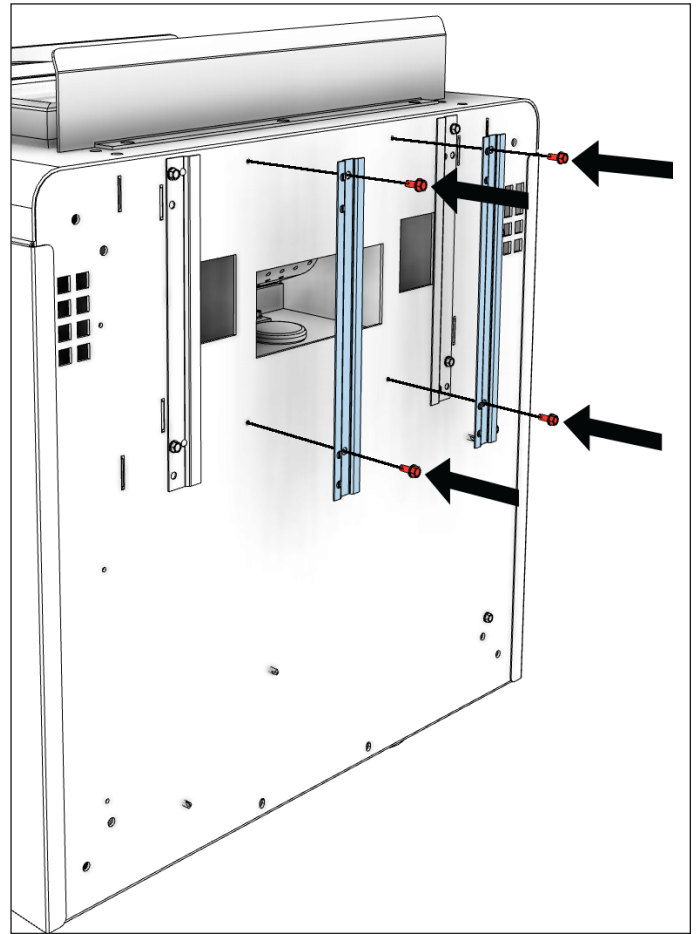

Twist the small brushed nickel spring handle onto the damper weldment.

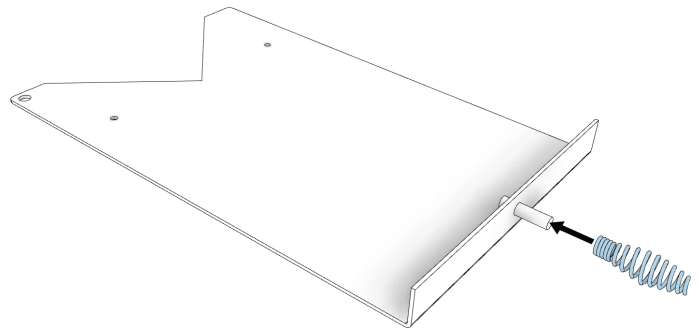

Slide the damper weldment and two lower ash clean-outs into the previously installed guides.

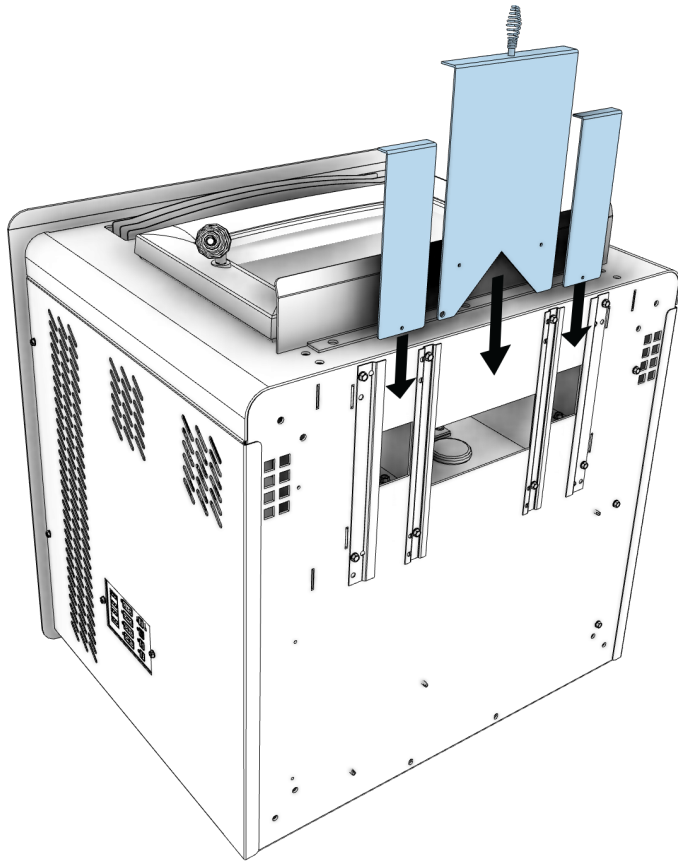

Install two (2) of the provided #10 screws to the damper weldment. Additionally, install one (1) of the provided #10 screws to each of the two lower ash clean-outs. These screws will serve as a stop mechanism to prevent the damper weldment and lower ash clean-outs from sliding out too far during operation.

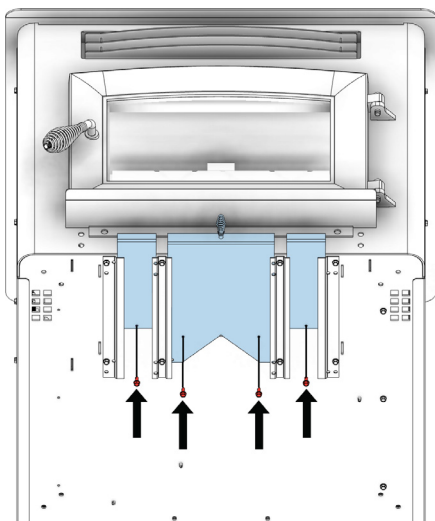

STOP!! Before proceeding prepare and position the stove for assembly of the pedestal to the stove.

NOTE: The stove is heavy and requires 2 or more people to move.

Place the assembled pedestal into the desired location. With the assistance of a second person, set the stove onto the pedestal base. Use the six (6) provided screws to secure the stove to the pedestal base.

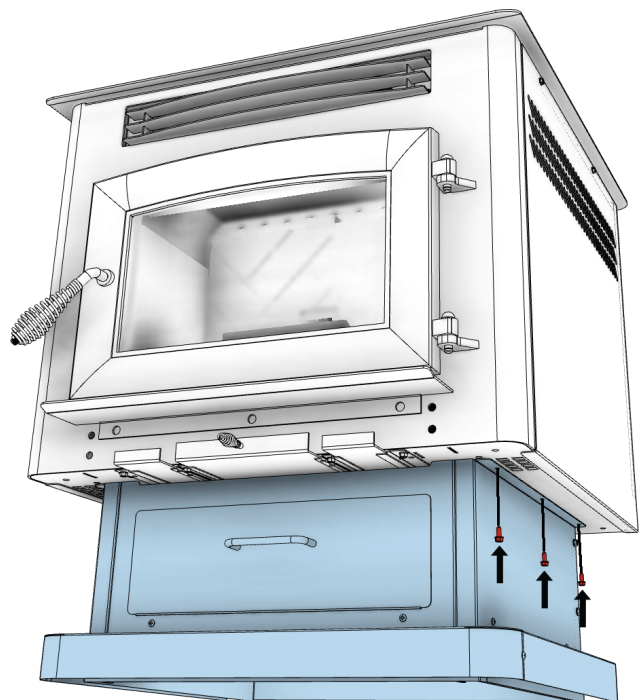
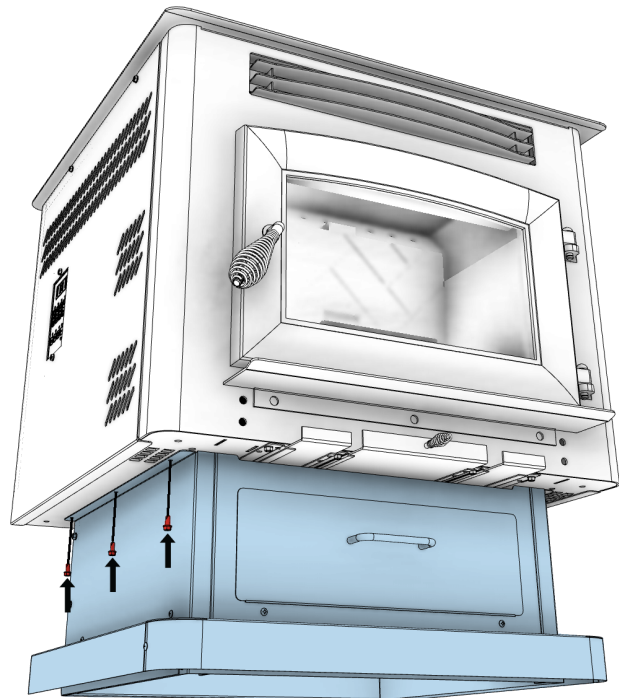

FOR CUSTOMER SERVICE CALL: 800-750-2723 EXT 5050

SAFETY NOTICE

- IF THIS STOVE IS NOT PROPERLY INSTALLED, A HOUSE FIRE MAY RESULT. TO REDUCE THE RISK OF FIRE, FOLLOW THE INSTALLATION INSTRUCTIONS.
- CONTACT YOUR LOCAL BUILDING OFFICIALS TO OBTAIN A PERMIT AND INFORMATION ON ANY ADDITIONAL INSTALLATION RESTRICTIONS OR INSPECTION REQUIREMENTS IN YOUR AREA.
- DO NOT PLACE CLOTHING OR OTHER FLAMMABLE ITEMS ON OR NEAR THIS STOVE.
- NEVER USE GASOLINE, GASOLINE-TYPE LANTERN FUEL, KEROSENE, CHARCOAL LIGHTER FLUID, OR SIMILAR LIQUIDS TO START OR 'FRESHEN UP' A FIRE IN THIS STOVE. KEEP ALL SUCH LIQUIDS WELL AWAY FROM THE STOVE WHILE IT IS IN USE.
- DO NOT CONNECT THIS HEATER TO "B" VENT. USE UL LISTED PELL VENT ONLY!
- DO NOT ELEVATE THE FIRE BY USE OF GRATE OR ANY OTHER MEANS OTHER THAN THE SUPPLIED BURNPOT.
- THIS WOOD HEATER NEEDS PERIODIC INSPECTION AND REPAIR FOR PROPER OPERATION. IT IS AGAINST FEDERAL REGULATIONS TO OPERATE THIS WOOD HEATER IN A MANNER INCONSISTENT WITH OPERATING INSTRUCTIONS IN THIS MANUAL.
- ALWAYS ROUTE THE POWER CORD AWAY FROM THE UNIT. DO NOT ROUTE CORD IN FOOT TRAFFIC AREAS. DO NOT PINCH CORD UNDER FURNITURE. DO NOT ROUTE THE CORD ACROSS THE EXHAUST PIPE.
- A POWER SURGE PROTECTOR IS REQUIRED. THE UNIT MUST BE PLUGGED INTO A GROUNDED 110-VOLT POWER SOURCE.

CAUTION:

BURNING FUEL CREATES CARBON MONOXIDE AND CAN BE HAZARDOUS TO YOUR HEALTH IF NOT PROPERLY VENTED.

ATTENTION:

- A WORKING SMOKE DETECTOR MUST BE INSTALLED IN THE SAME ROOM AS THIS PRODUCT.
- INSTALL A SMOKE DETECTOR ON EACH FLOOR OF YOUR HOME; IN CASE OF ACCIDENTAL FIRE FROM ANY CAUSE IT CAN PROVIDE TIME FOR ESCAPE.
- THIS HEATER IS NOT INTENDED FOR USE IN COMMERCIAL INSTALLATIONS.
- THIS PRODUCT REQUIRES SIMPLE PERIODIC MAINTENANCE FOR PROPER OPERATION AND LONG LIFE OF THE HEATER. READ AND FOLLOW THE MAINTENANCE SCHEDULE CLOSELY.

CAUTION:

- DO NOT UNPLUG THE STOVE IF YOU SUSPECT A MALFUNCTION. TURN THE ON/OFF SWITCH TO "OFF" AND CONTACT YOUR DEALER.
- THE HEATER WILL NOT OPERATE DURING A POWER OUTAGE. IF A POWER OUTAGE DOES OCCUR, CHECK THE HEATER FOR SMOKE SPILLAGE AND OPEN A WINDOW IF ANY SMOKE SPILLS INTO THE ROOM.



We recommend that our woodburning hearth products be installed and serviced by professionals who are certified in the U.S. by the National Fireplace Institute® (NFI) as NFI Woodburning Specialists or who are certified in Canada by Wood Energy Technical Training (WETT).



Your heater should be installed by a qualified NFI (US) or WETT (Canada) technician. To find the nearest qualified installer, go to:

<https://nficertified.org>,

<https://www.wettinc.ca/>

AIR INTAKE & EXHAUST LOCATIONS

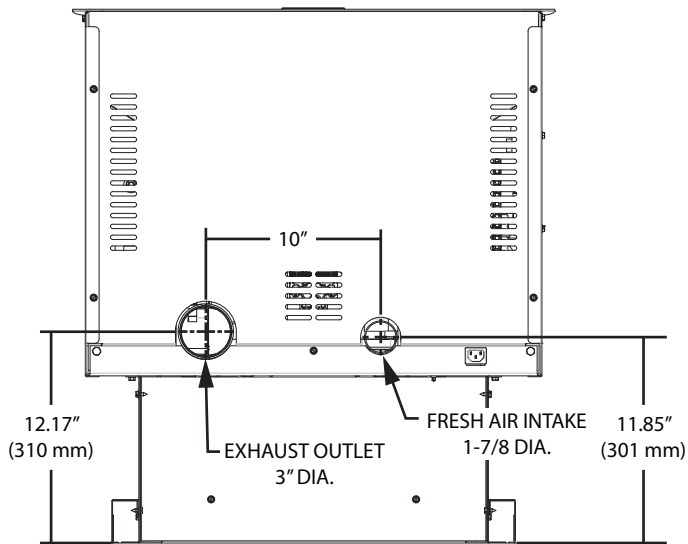

FLOOR PROTECTION

This heater may be installed on a combustible floor, with proper floor protection, or on a masonry hearth. The hearth or noncombustible floor protector must extend a minimum of 6" (152mm) in front and 6" (152mm) from each side of the unit.

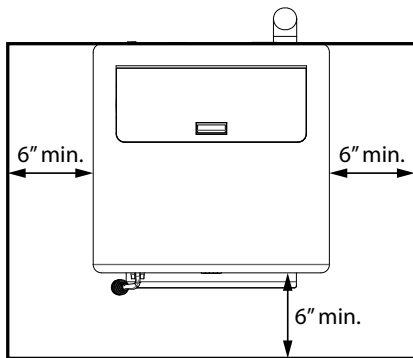

Floor Protection

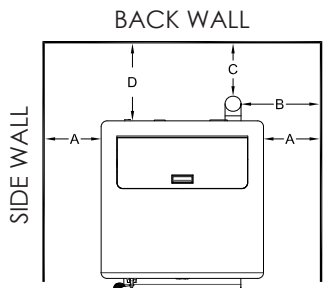

Backwall / Sidewall Parallel

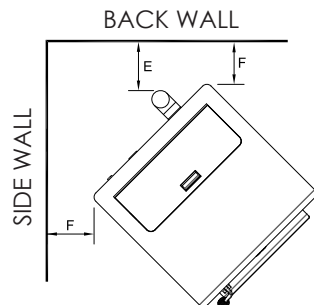

Corner Installation

		in	mm
PARALLEL	A	Side wall to Top Edge of Unit	8 203
	B	Side wall to Flue	13 330
	C	Back wall to Flue	3 75
	D	Back wall to Unit	9 228
CORNER	E	Adjacent Wall to Flue	3 75
	F	Adjacent Wall to Unit	4 100

OUTSIDE AIR SUPPLY (OPTIONAL, UNLESS INSTALLING IN A MOBILE HOME)

Depending on your location and home construction, outside air may be necessary for optimal performance. Your stove is approved to be installed with an outside air intake (69FAK) which is necessary for a mobile home. You can purchase the 69FAK through your heater dealer. Installation instructions are supplied with the air intake kit.

ATTENTION:

DO NOT VENT UNDER ANY PORCH, DECK, AWNING, OR IN ANY SEMI ENCLOSED OR ROOFED AREA. DOING SO MAY RESULT IN UNPREDICTABLE AIRFLOW AT THE VENT CAP UNDER CERTAIN CONDITIONS AND CAN AFFECT THE PERFORMANCE OF YOUR STOVE, AS WELL AS OTHER UNFORESEEABLE ISSUES.

WARNING! DO NOT INSTALL IN SLEEPING ROOM.

CAUTION! THE STRUCTURAL INTEGRITY OF THE MOBILE HOME FLOOR, WALL, AND CEILING/ROOF MUST BE MAINTAINED.

WHEN INSTALLED IN A MOBILE HOME, THE STOVE MUST BE GROUNDED DIRECTLY TO THE STEEL CHASSIS AND BOLTED TO THE FLOOR.

In addition to the previously detailed installation requirements, mobile home installations must meet the following requirements:

- This stove must be securely fastened to the floor of the mobile home using two 1/4" lag bolts that are long enough to go through both a hearth pad, if used, and the floor of the home.
- The heater must be electrically grounded to the steel chassis of the mobile home with 8 GA copper wire using a serrated or star washer to penetrate paint or protective coating to ensure grounding.

- Vent must be 3 or 4-inch “PL” Vent and must extend a minimum of 36” (914 mm) above the roof line of the mobile home and must be installed using a certified ceiling fire stop and rain cap.
- When moving your mobile home, all exterior venting must be removed while the mobile home is being relocated. After relocation, all venting must be reinstalled and securely fastened.
- Outside Air is mandatory for mobile home installation. See Outside Air Supply section and your dealer for purchasing.
- Check with your local building officials as other codes may apply.

VENTING REQUIREMENTS

A compatible appliance adapter is required for the proper venting installation of this unit. Purchase the appropriate appliance adapter from your preferred venting company prior to starting the ventilation process.



INSTALL VENT AT CLEARANCES SPECIFIED BY THE VENT MANUFACTURER

- A UL listed 3” or 4” type “PL” pellet vent exhaust system must be used for installation and attached to the pipe connector provided on the back of the heater. Use a 3” to 4” adapter for 4” pipe. A 4” PL is required for elevations above 2,500 feet above sea level.
- Do not terminate vent in any enclosed or semi-enclosed area, such as; carports, garage, attic, crawl space, under a sundeck or porch, narrow walkway or close area, or any location that can build up a concentration of fumes such as a stairwell, covered breezeway etc.
- Vent surfaces can get hot enough to cause burns if touched by children. Noncombustible shielding or guards may be required.
- Do not install a flue damper in the exhaust vent of this unit.

- Termination must exhaust above air inlet elevation. Installation MUST include three (3) vertical feet of pellet vent pipe. This will create some natural draft to prevent the possibility of smoke or odor during appliance shutdown and to keep exhaust from causing a nuisance or hazard from exposing people or shrubs to high temperatures. Do not connect this unit to a chimney flue serving another appliance. Do not connect directly to a masonry chimney.
- The installation must include a cleanout tee to enable collection of fly ash and to permit periodic cleaning of the exhaust system. 90° elbows accumulate fly ash and soot thereby reducing exhaust flow and performance of the heater. Each elbow or tee reduces draft potential by 30% to 50%. Use no more than 180 degrees of elbows (two 90° elbows, or two 45° and one 90° elbow, etc.) and one cleanout tee to maintain adequate draft. Cleanout tees and elbows should not be connected to the rear of the unit unless a 3-inch adapter is used.
- Total length of horizontal vent must not exceed 48” (4ft.)/1,200mm. The maximum recommended vertical venting height is 12-feet for 3-inch type “PL” vent. For venting higher than 12-feet, 4-inch “PL” vent must be used. All joints in the vent system must be fastened by at least 3 screws, and all joints must be sealed with RTV silicone sealer to be airtight.
- The area where the vent pipe penetrates to the exterior of the home must be sealed with silicone or other means to maintain the vapor barrier between the exterior and the interior of the home.

NOTE: These are guidelines only. Proper venting is accomplished by design and necessary requirements. In most installations 3 inch diameter venting is adequate. If it does not vent properly you will have to change it to 4 inches. You should not exceed 4 inch diameter venting.

DO NOT CONNECT TO ANY AIR DISTRIBUTION DUCT OR SYSTEM

IMPORTANCE OF PROPER DRAFT

Draft is the force which moves air from the appliance up through the chimney. The amount of draft in your chimney depends on the length of the chimney, local geography, nearby obstructions and other factors. Too much draft may cause excessive temperatures in the appliance. Inadequate draft may cause backpuffing into the room and ‘plugging’ of the chimney. Inadequate draft will cause the appliance to leak smoke into the room through appliance and chimney connector joints. An uncontrollable burn or excessive temperature indicates excessive draft. Take into account the chimney’s location to ensure it is not too close to neighbors or in a valley

which may cause unhealthy or nuisance conditions. It is recommended that only an authorized installer install your heater, preferably an NFI certified specialist. The following installation guidelines must be followed to ensure conformity with both the safety listing of this heater and to local building codes.

VENT TERMINATION CLEARANCES

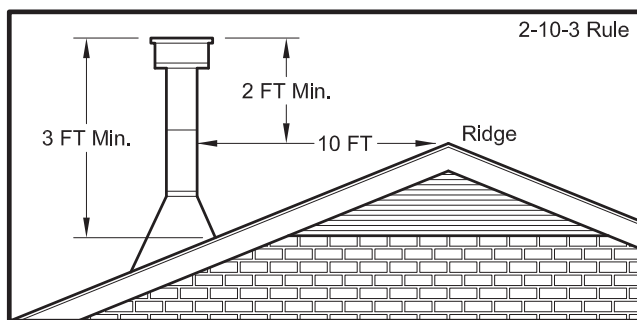
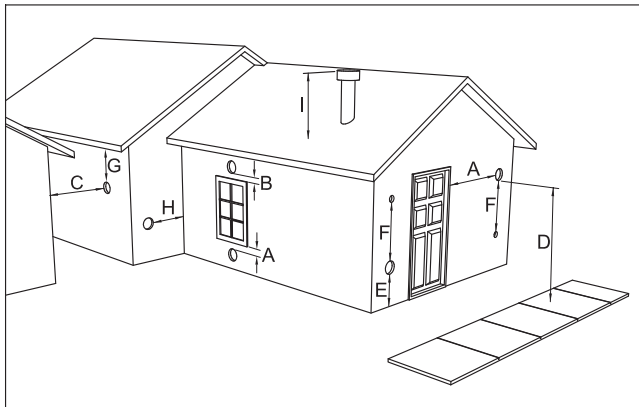

- A. Min. 4-ft clearance below or beside any door or window that opens.
- B. Min. 1-ft clearance above any door or window that opens.
- C. Min. 3-ft clearance from any adjacent building.
- D. Min. 7-ft clearance from any grade when adjacent to public walkways.
- E. Min. 2-ft clearance above any grass, plants, or other combustible materials.
- F. Min. 3-ft clearance from a forced air intake of any appliance.
- G. Min. 2-ft clearance below eaves or overhang.
- H. Min. 1-ft clearance horizontally from combustible wall.
- I. Must be a minimum of 36-inches above the roof and 24-inches above the highest point or the roof within 10-feet.

DESIGN GUIDELINES FOR OUTSIDE COMBUSTION AIR CONNECTION

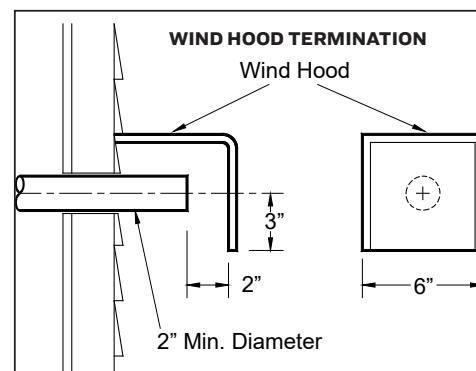
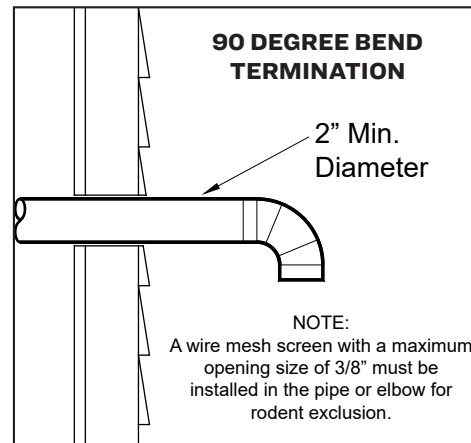

1. For installations with horizontal through-the-wall exhaust, it is strongly recommended that the heater combustion air be connected to the outside. If the home is newer or has been tightly insulated, it is required to install outside combustion air.
2. Connection to outside the house is **REQUIRED** for mobile home installations. We strongly urge use of the 69FAK Fresh Air Kit.
3. Only noncombustible pipe 2 inches (or greater) in diameter is approved to use for outside air connections (straight or flexible). PVC pipe is **NOT** approved and should **NEVER** be used.
4. If the air inlet is connected to the outside, it **MUST** be terminated with a vertical 90-degree bend (down) or with a wind hood. Failure to do so could result in a burn back during high winds blowing directly up the air inlet during a simultaneous power failure (see diagram above).
5. Blockage, excessive length, or extra bends in the air intake pipe will starve the heater of combustion air. A 90-degree bend is equivalent in restriction to approximately 30 inches of straight inlet pipe.

CAUTION:

THE OPERATION OF EXHAUST FANS SUCH AS BATH ROOM FANS, ATTIC FANS, ETC. MIGHT STARVE THE HEATER OF COMBUSTIBLE AIR CREATING A NEGATIVE PRESSURE IN THE ROOM. PROVIDE ADEQUATE VENTILATION IN THE ROOM ACCOMPANYING THE HEATER. IF NOT, THE PRESSURE SWITCH MAY SHUT OFF OPERATION OF THE HEATER. (DUE TO NEGATIVE PRESSURE)

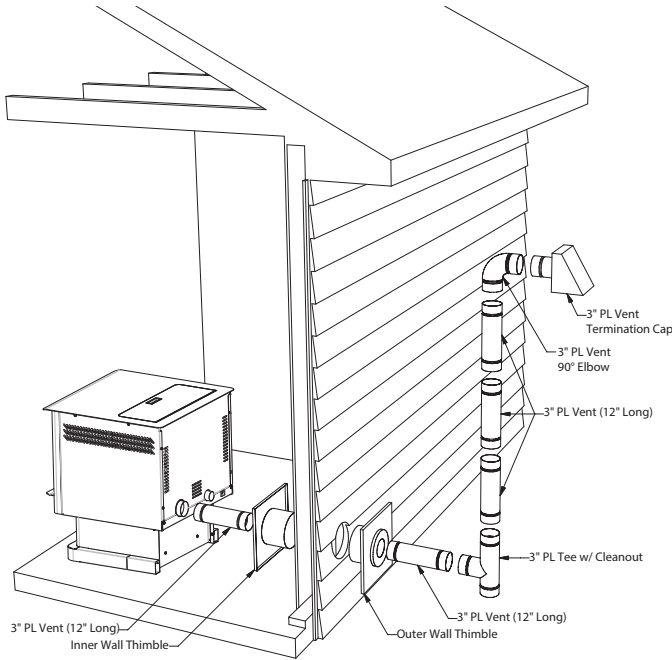

A MINIMUM OF 3 VERTICAL FEET OF PIPE OUTSIDE THE HOME IS REQUIRED!

THROUGH THE WALL, VERTICAL PIPE INSTALLATION WITH TERMINATION CAP

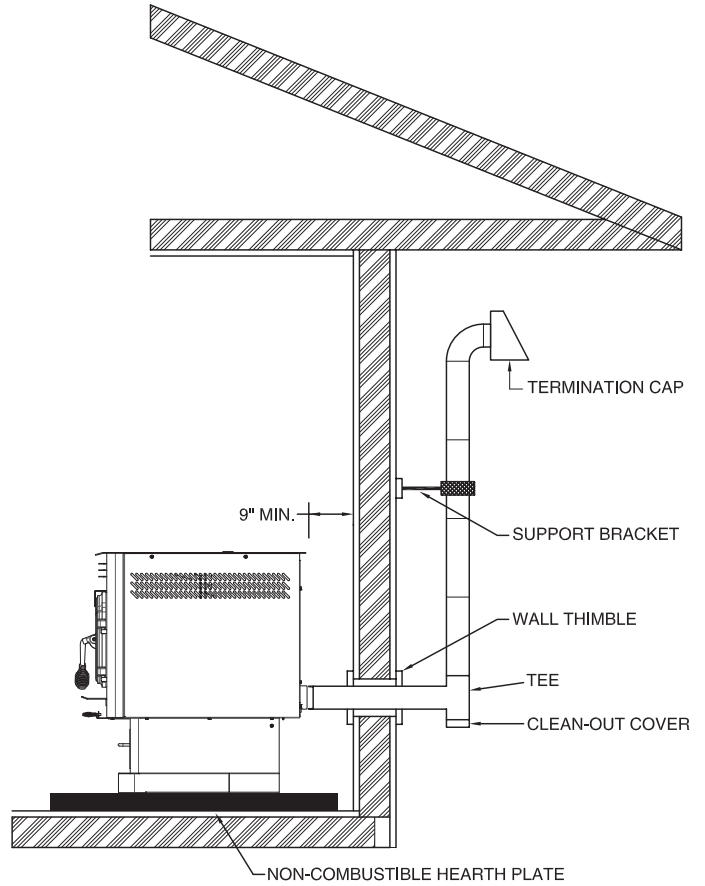

A MINIMUM OF 3 VERTICAL FEET OF PIPE OUTSIDE THE HOME IS REQUIRED!

NEVER OPERATE THIS PRODUCT WHILE UNATTENDED

UNDERSTANDING THE CONTROL BOARD

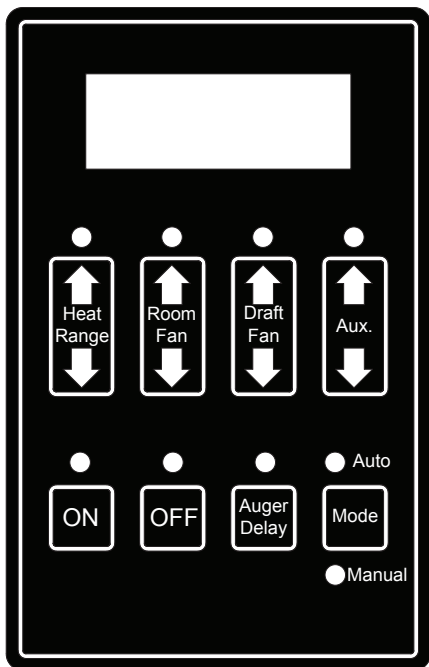

Turning the heater OFF/ON, as well as adjustments for the fuel feed rate and room fan speed are performed by pressing the appropriate button(s) on the control panel.

This unit has two fuel operation modes. It may also be changed between an automatic operation or a manual operation in either of the fuel modes.

- Pressing the “ON” button on the control panel will begin the start-up sequence for the heater. The start-up sequence differs depending on which fuel operation mode you select (see Lighting Instructions for details). Pressing and holding the “ON” button will rotate the auger continuously until the button is released, which feeds additional fuel.
- Pressing the “OFF” button on the control panel will cause the heater to enter its shut-down sequence. The fuel feed system will stop pulling fuel from the hopper and, once the fire goes out and the heater cools down, the fans will stop running.
- Pressing the “Heat Range” arrows, up or down, will adjust the amount of fuel being delivered to the burnpot.
- The draft fan (exhaust) will come on as soon as the “ON” button is pressed. The fan will automatically adjust its speed in accordance to the heat range setting. However, this speed can be manually operated by

pressing the “Draft Fan” arrows up or down. “Draft Fan” when pressed, the display will show “DF-A”, which is automatic. Press the arrows again to adjust fan speed. When adjusting the draft fan setting, try only

- One setting above or below the heat setting. It is better to leave the heater in the automatic mode and adjust the manual draft slide to control the combustion air.
- The room fan will come on once the unit has reached operating temperature (approx. 110°F). By pressing the “Room Fan” buttons, the display will show “RF-A” which is automatic or “RF-1” through “RF-9” for manual settings. In auto mode, the room fan’s speed will automatically be adjusted in accordance with the heat range setting. By pressing the “Room Fan” up arrow, you can adjust the fan speed setting up to “RF-9”. The fan speed can be adjusted to a higher setting than the heat setting but not lower than the corresponding heat range.
- The “Aux” button is for Agitator operation. When the unit is “OFF” and the heater is cool, pressing the “Aux” arrows will rotate the agitator for easy removal for cleaning. The agitator, when in Automatic mode, will operate at set intervals. However, these can be changed by pressing the arrows on the “Aux” button. The agitator can be adjusted from 0 to 9, setting “0” is off and setting “9” is high.
- The “Auger Delay” button can be used to pause rotation of the Auger and Agitator for approx. 1 minute. This can be cancelled by pressing the “ON” button. The “Auger Delay” is normally used only during the start up cycle to slow the fuel delivery down during the initial ignition.
- The “Mode” button is used to switch between manual and automatic mode. When in auto mode, the fan, auger, and agitator will operate at preset intervals unless changed manually using the buttons mentioned above. When in manual mode, the draft fan (exhaust) will operate at full speed (100%), so the air must be controlled with the manual slide damper just below the viewing door. When the heater is in the manual mode, the optional thermostat will not properly control the unit.
- During normal operation, the unit is constantly monitored for problems. In the event of an error condition, the unit will stop and an error will be displayed. See the list of error codes found at the end of this manual.

WARNING:

- **DO NOT USE CHEMICALS OR FLUIDS TO START THE FIRE - NEVER USE GASOLINE, GASOLINE-TYPE LANTERN FUEL, KEROSENE, CHARCOAL LIGHTER FLUID, OR SIMILAR LIQUIDS TO START OR “FRESHEN UP” A FIRE IN THIS STOVE. KEEP ALL SUCH LIQUIDS WELL AWAY FROM THE STOVE WHILE IT IS IN USE.**
- **HOT WHILE IN OPERATION. KEEP CHILDREN, CLOTHING AND FURNITURE AWAY. CONTACT MAY CAUSE SKIN BURNS.**

DO NOT BURN:

1. Garbage;
2. Lawn clippings or yard waste;
3. Materials containing rubber, including tires;
4. Materials containing plastic;
5. Waste petroleum products, paints or paint thinners, or asphalt products;
6. Materials containing asbestos;
7. Construction or demolition debris;
8. Railroad ties or pressure-treated wood;
9. Manure or animal remains;
10. Salt water driftwood or other previously salt water saturated materials;
11. Unseasoned wood; or
12. Paper products, cardboard, plywood, or particleboard. The prohibition against burning these materials does not prohibit the use of fire starters made from paper, cardboard, saw dust, wax and similar substances for the purpose of starting a fire in an affected wood heater.

Burning these materials may result in release of toxic fumes or render the heater ineffective and cause smoke.

PROPER FUEL

ATTENTION:

THIS APPLIANCE IS DESIGNED FOR THE USE OF PELLETIZED FUEL THAT MEET OR EXCEED THE STANDARD SET BY THE PELLET FUEL INSTITUTE (PFI). IN ADDITION TO PELLET FUEL, THIS STOVE IS APPROVED BY THE EPA TO BURN DRIED CORN.

Your multi-fuel stove is designed to burn premium hardwood pellets that comply with the Pellet Fuels Institute (PFI) standard (minimum of 40 lbs density

per cubic ft, 1/4” to 5/16” diameter, length no greater than 1.5”, not less than 8,200 BTU/lb, moisture under 8% by weight, ash under 1% by weight, and salt under 300 parts per million). Pellets that are soft, contain excessive amounts of loose sawdust, have been, or are wet, will result in reduced performance. Store your pellets in a dry place. DO NOT store the fuel within the installation clearances of the unit or within the space required for refuelling and ash removal. Doing so could result in a house fire. Do not over fire or use volatile fuels or combustibles, doing so may cause a personal and property damage hazards. Factory-approved pellets are those 1/4” or 5/16” in diameter and not over 1” long. Longer or thicker pellets sometimes bridge the auger flights, which prevents proper pellet feed. Burning wood in forms other than pellets is not permitted. It will violate the building codes for which the stove has been approved and will void all warranties. The design incorporates automatic feed of the pellet fuel into the fire at a carefully prescribed rate. Any additional fuel introduced by hand will not increase heat output but may seriously impair the stoves performance by generating considerable smoke. Do not burn wet pellets. The stove’s performance depends heavily on the quality of your pellet fuel. Avoid pellet brands that display these characteristics:

- Excess Fines – “Fines” is a term describing crushed pellets or loose material that looks like sawdust or sand. Pellets can be screened before being placed in hopper to remove most fines.
- Binders – Some pellets are produced with materials to hold the together, or “bind” them.
- High ash content – Poor quality pellets will often create smoke and dirty glass. They will create a need for more frequent maintenance. You will have to empty the burn pot plus vacuum the entire system more often. Poor quality pellets could damage the auger. We cannot accept responsibility for damage due to poor quality pellet.
- Your corn needs to be clean and dry, and you should never burn any seed corn or other chemically treated corn, old corn, corn with mildew or mold, etc.
- Corn should be dried to 11-12%. If you are buying corn from a retail supplier, make sure it is intended to be sold (and burned) as fuel. If you are buying direct from a farmer in bulk, make sure you communicate what you are doing with the corn and that you need it dried sufficiently so you don’t have problems.
- If your corn has too much moisture, it will cause a variety of problems including lighting, consistent flame and heat, smoke, and more.

- Corn burns hotter than wood pellets. Be prepared for more heat output. Sometimes a corn burning appliance can heat your home to your desired temp on its lowest level. When you first start burning corn, especially if you're used to wood pellets, you'll want to start out on a lower setting and slowly turn it up as needed.
- When you burn corn, you'll occasionally get "Klinkers" which is a build up. You can eliminate or greatly reduce any buildup of the Klinker by making sure that your corn is free from dust, dirt, corn fines, pieces of stalk and other debris. Having your fuel at 11-12 percent moisture will also help out in reducing the Klinker buildup. Remember that you can mix corn with wood pellets. Doing so will extend one fuel, as well as help avoid klinkers.

CAUTION:

- **KEEP FOREIGN OBJECTS OUT OF THE HOPPER.**
- **THE MOVING PARTS OF THIS STOVE ARE PROPELLED BY HIGH TORQUE ELECTRIC MOTORS. KEEP ALL BODY PARTS AWAY FROM THE AUGER WHILE THE STOVE IS PLUGGED INTO AN ELECTRICAL OUTLET. THESE MOVING PARTS MAY BEGIN TO MOVE AT ANY TIME WHILE THE STOVE IS PLUGGED IN.**

PRE-START-UP CHECK

Remove burn pot, making sure it is clean and none of the air holes are plugged. Clean the firebox, and then reinstall burn pot. Clean door glass if necessary (a dry cloth or paper towel is usually sufficient). Never use abrasive cleaners on the glass or door. Choose which fuel setting that you wish to operate in. Do this by first pressing the "ON" button, then press the "Heat Range" Up and Down arrows together for approximately 3-4 seconds and release. A "C" or "P" in the first digit of the display will indicate the mode. The "ON" led will be blinking and the display will show "CR-1" or "PR-1", depending on the mode. The "Heat Range" indicator LED and the "Auto" LED should be lit and the dash in the Heat Range display should be flashing. You will notice the draft fan starts immediately. If you press the "Heat Setting" button up, the draft fan changes speed, increasing speed the higher the heat setting. You should begin to see the igniter, located in the center and behind the burnpot, begin to glow after a short period of time. In CR-1, the auger and agitator will start rotating after a few minutes, allowing for proper fuel ignition. In PR-1, the auger will turn immediately, then the agitator will begin to rotate once the heater reaches operating temperature. Note: The room fan will not operate at this time, as a temperature of at least 110°F

must be reached before operating. If proper operation of your heater is confirmed, press the "OFF" button, then fill your hopper with fuel. Ensure there is no foreign matter in your fuel, hopper or burnpot.

BUILDING A FIRE

Never use a grate or other means of supporting the fuel. Use only the burn pot supplied with this heater. Hopper lid must be closed in order for the unit to feed pellets. During the start-up period:

- Make sure the burn pot is free of pellets.
- DO NOT open the viewing door.
- DO NOT add pellets to the burn pot by hand.

NOTE: During the first few fires, your stove will emit an odor as the high-temperature paint cures or becomes seasoned to the metal. Maintaining smaller fires will minimize this. Avoid placing items on the stovetop during this period because the paint could be affected. Attempts to achieve heat output rates that exceed heater design specifications can result in permanent damage to the heater.

OPTIMAL OPERATION

This multi-fuel stove has been certified by the US EPA to meet strict 2020 guidelines. To Insure this unit produces the optimal minimal emissions, it is critical to follow the following guidelines. To achieve a "high burn" your stove should be set on setting 5 with the damper fully open. To achieve a "medium burn" your stove should be set on setting 1 with the damper fully closed. To achieve a "low burn" your stove should be set on setting 1 with the damper closed. Settings 2, 3 & 4 will give you a higher heat output above medium and the damper should be open for these settings. If the door is opened while the stove is in operation it must be closed within 30 seconds or the stove will shut down. If the stove shuts down push the "On/Off" button to re-start your stove. The stove will have to fully shut down and turn off before you will be able to restart the stove.

IGNITOR

- Close all doors, lids, and cleanouts.
- Press the "ON" button and select desired heat range. This will start the ignition sequence.
- At this point, the igniter will come on and run for preset time limit (approximately 9 minutes). The auger will begin to turn and feed fuel into the burnpot. After the 9 minutes or if the heater reaches operating temperature, the igniter will shut off and normal operation will begin.

- Make fine adjustments to the air/fuel with the damper located centered, under the hearth.
- Once the heater reaches warm temperature, the room fan will start to circulate air into the room.
- If you would like to increase the life of your ignitor, you can run your heater in the “CR” mode. However, you must place pellets in the burnpot, up to the igniter level as shown in the illustration below for auto ignition. Close the door and press the “ON” button. The igniter only runs approximately half the time in “CR” as oppose to the “PR” mode.

OPENING DOOR

CAUTION:
<ul style="list-style-type: none">• DO NOT OPERATE YOUR STOVE WITH THE VIEWING DOOR OPEN. THE AUGER WILL NOT FEED PELLETS UNDER THESE CIRCUMSTANCES AND A SAFETY CONCERN MAY ARISE FROM SPARKS OR FUMES ENTERING THE ROOM.• THE DOOR MUST BE CLOSED AND SEALED DURING OPERATION.

If the door is opened while the stove is in operation it must be closed within 30 seconds or the stove will shut down. If the stove shuts down push the “On/Off” button to re-start your stove. The stove will have to fully shut down and turn off before you will be able to restart the stove.

TAMPER WARNING

This wood heater has a manufacturer-set minimum low burn rate that must not be altered. It is against federal regulations to alter this setting or otherwise operate this wood heater in a manner inconsistent with operating instructions in this manual.

REFUELLING

WARNING:
<ul style="list-style-type: none">• KEEP HOPPER LID CLOSED AT ALL TIMES EXCEPT WHEN REFILLING.• DO NOT OVERFILL HOPPER.

CAUTION:
<ul style="list-style-type: none">• NEVER PLACE YOUR HAND NEAR THE AUGER WHILE THE STOVE IS IN OPERATION.• WE RECOMMEND THAT YOU NOT LET THE HOPPER DROP BELOW 1/4 FULL.

CAUTION:
<ul style="list-style-type: none">• THE HOPPER AND STOVE TOP WILL BE HOT DURING OPERATION; THEREFORE, YOU SHOULD ALWAYS USE SOME TYPE OF HAND PROTECTION WHEN REFUELING YOUR STOVE.• DO NOT TOUCH THE HOT SURFACES OF THE STOVE. EDUCATE ALL CHILDREN ON THE DANGERS OF A HIGH-TEMPERATURE STOVE. YOUNG CHILDREN SHOULD BE SUPERVISED WHEN THEY ARE IN THE SAME ROOM AS THE STOVE.

SHUTDOWN PROCEDURE

WARNING:
NEVER SHUT DOWN THIS UNIT BY UNPLUGGING IT FROM THE POWER SOURCE.

Pressing the OFF button will cause the heater to enter a shutdown mode. If the heater has reached operating temperature, the “OFF” Indicator will blink until the shutdown procedure succeeds in lowering the heater temperature. The Room Fan will stay on to cool the heater, and the Exhaust Fan will stay on to remove smoke and heat from the combustion chamber. The Agitator will rotate continuously until shutdown is complete. The Auger will bump the fuel out every few seconds to prevent the fuel in the auger from burning. Once the temperature of the burn chamber falls below approximately 90°F and the pressure switch detects that the door is closed, the fans will stop and the Auger will run for a few seconds to purge the auger system of any burned fuel. At this point, the “OFF” Indicator will go out and the heater will turn completely off. If during burning, the heater reached at least 120°F, the shutdown procedure will include a 15 minute shutdown cycle that will keep the heater in the shutdown state for at least 15 minutes regardless of whether it is cool or pressure is detected. The 15 minute cycle can be turned off by pressing the off button during shutdown. This will cause the system to exit shutdown and return to the “OFF” mode as soon as the door is closed and the heater is cool. Continue to monitor the heater / insert after the shutdown procedure has begun. And remember, varying ambient conditions may result in a lengthy period of time for adequate cool down and the resultant shut down. Be patient, this is normal. The control board is telling the heater / insert to gradually “shut down,” rather than initiate a sudden halt of fuel to the fire pot. In this way, the possibility of smoke entering the home is avoided.

INTERIOR CHAMBERS

- Periodically remove and clean the burn pot and the area inside the burn pot housing. In particular, it is advisable to clean out the holes in the burn pot to remove any build up that may prevent air from moving through the burn pot freely.
- Remove the small clean-out slides in the lower corners of the firebox. Tap the sides of the burn chamber with a wooden stick. Do not tap the firewall behind the burn box as it may damage the ceramic firebrick. Scrape the fly ash from the clean-out chambers toward the front of the burn chamber. Remove the fly ash from the burn chamber and replace the clean-outs.

- Remove the ash pan and dump the ash into a metal container.
- Cleaning of the exhaust system will depend upon the ash and debris content of your fuel. If your fuel has a high ash content and/or significant debris in it, your exhaust system will require weekly cleaning. Cleaner fuels will allow for monthly cleaning of the exhaust system. Remove the exhaust pipe from the back of your heater and remove any ash that may have collected in the pipes. Replace the pipes to the heater and seal with high temperature seal tape. If you have installed proper clean out tees you will not have to take the chimney sections apart.

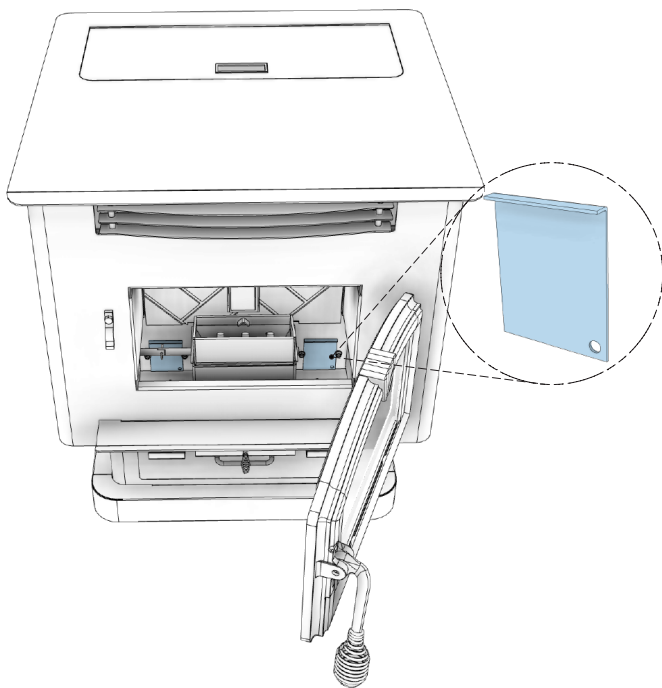

NEVER OPERATE THIS PRODUCT WHILE UNATTENDED

CAUTION:

- **FAILURE TO CLEAN AND MAINTAIN THIS UNIT AS INDICATED CAN RESULT IN POOR PERFORMANCE, SAFETY HAZARDS, FIRE, AND EVEN DEATH.**
- **NEVER PERFORM ANY INSPECTIONS, CLEANING, OR MAINTENANCE ON A HOT STOVE.**
- **DISCONNECT THE POWER CORD BEFORE PERFORMING ANY MAINTENANCE! NOTE: TURNING THE ON/OFF SWITCH TO "OFF" DOES NOT DISCONNECT ALL POWER TO THE ELECTRICAL COMPONENTS OF THE STOVE.**
- **DO NOT OPERATE STOVE WITH BROKEN GLASS, LEAKAGE OF FLUE GAS MAY RESULT.**
- **ATTEMPTS TO ACHIEVE HEAT OUTPUT RATES THAT EXCEED HEATER DESIGN SPECIFICATIONS CAN RESULT IN PERMANENT DAMAGE TO THE HEATER.**

CREOSOTE FORMATION, INSPECTION, & REMOVAL

CAUTION:

THE EXHAUST SYSTEM SHOULD BE CHECKED MONTHLY DURING THE BURNING SEASON FOR ANY BUILD-UP OF SOOT OR CREOSOTE.

When any wood is burned slowly, it produces tar and other organic vapors, which combine with expelled moisture to form creosote. The creosote vapors condense in the relatively cool chimney flue or a newly started fire or from a slow-burning fire. As a result, creosote residue accumulates on the flue lining. When ignited, this creosote makes an extremely hot fire, which may damage the chimney or even destroy the house. Despite their high efficiency, pellet stoves can accumulate creosote under certain conditions. The chimney connector and chimney should be inspected by a qualified person annually or per ton of pellets to determine if a creosote or fly ash build-up has occurred. If creosote has accumulated, it should be removed to reduce the risk of a chimney fire. Inspect the system at the stove connection and at the chimney top. Cooler surfaces tend to build creosote deposits quicker, so it is important to check the chimney from the top as well as from the bottom. The creosote should be removed with a brush specifically designed for the

type of chimney in use. A qualified chimney sweep can perform this service. It is also recommended that before each heating season the entire system be professionally inspected, cleaned and, if necessary, repaired. To clean the chimney, disconnect the vent from the stove.

FLY ASH

This accumulates in the horizontal portion of an exhaust run. Though non-combustible, it may impede the normal exhaust flow. It should therefore be periodically removed.

ASH REMOVAL & DISPOSAL

CAUTION:

ALLOW THE STOVE TO COOL BEFORE PERFORMING ANY MAINTENANCE OR CLEANING. ASHES MUST BE DISPOSED IN A METAL CONTAINER WITH A TIGHT FITTING LID. THE CLOSED CONTAINER OF ASHES SHOULD BE PLACED ON A NON-COMBUSTIBLE SURFACE OR ON THE GROUND, WELL AWAY FROM ALL COMBUSTIBLE MATERIALS, PENDING FINAL DISPOSAL.

Remove the ashes periodically to avoid unnecessary ash build up. Remove ashes when unit has cooled. Ashes should be placed in a metal container with a tight fitting lid. The closed container of ashes should be placed on a noncombustible floor or on the ground, well away from all combustible materials, pending final disposal. If the ashes are disposed of by burial in soil or otherwise locally dispersed, they should be retained in the closed container until all embers have been thoroughly cooled. The container shall not be used for other trash or waste disposal. If combined with combustible substances, ashes and embers may ignite.

SMOKE & CO MONITORS

Burning wood naturally produces smoke and carbon monoxide(CO) emissions. CO is a poisonous gas when exposed to elevated concentrations for extended periods of time. While the modern combustion systems in heaters drastically reduce the amount of CO emitted out the chimney, exposure to the gases in closed or confined areas can be dangerous. Make sure you stove gaskets and chimney joints are in good working order and sealing properly to ensure unintended exposure. It is recommended that you use both smoke and CO monitors in areas having the potential to generate CO.

CHECK & CLEAN THE HOPPER

Check the hopper periodically to determine if there is any sawdust (fines) that is building up in the feed system or pellets that are sticking to the hopper surface. Clean as needed.

DOOR & GLASS GASKETS

Inspect the main door and glass window gaskets periodically. The main door may need to be removed to have frayed, broken, or compacted gaskets replaced by your authorized dealer. This unit's door uses a 1" diameter rope gasket.

BLOWER MOTORS

Clean the air holes on the motors of both the exhaust and distribution blowers annually. Remove the exhaust blower from the exhaust duct and clean out the internal fan blades as part of your fall start-up. If you have indoor pets your power motors should be inspected monthly to make sure they are free of animal hair build up. Animal hair build up in blowers can result in poor performance or unforeseen safety hazards.

PAINTED SURFACES

Painted surfaces may be wiped down with a damp cloth. If scratches appear, or you wish to renew your paint, contact your authorized dealer to obtain a can of suitable high-temperature paint.

GLASS

We recommend using a high-quality glass cleaner. Should a buildup of creosote or carbon accumulate, you may wish to use 000 steel wool and water to clean the glass. DO NOT use abrasive cleaners. DO NOT perform the cleaning while the glass is HOT. Do not attempt to operate the unit with broken glass. Replacement glass may be purchased from your U.S. Stove dealer. If the glass is broken, follow these removal procedures:

1. Once the heater has cooled, remove the door from the heater.
2. Remove the rope gasket from the door followed by the nuts holding the glass retainer in place.
3. While wearing gloves, carefully remove any loose pieces of glass from the door frame.
4. Replace the glass and gasket, making sure the gasket runs the full perimeter of the glass edge.
5. Re-install the retainer and rope gasket using high-temperature silicone to adhere the gasket to the door.
6. Never use substitute materials for the glass.

DO NOT abuse the door glass by striking, slamming, or similar trauma. Do not operate the stove with the glass removed, cracked, or broken.

FALL START UP

Prior to starting the first fire of the heating season, check the outside area around the exhaust and air intake systems for obstructions. Clean and remove any fly ash from the exhaust venting system. Clean any screens on the exhaust system and on the outside air intake pipe. Turn all of the controls on and make sure that they are working properly. This is also a good time to give the entire stove a good cleaning throughout.

SPRING SHUTDOWN

After the last burn in the spring, remove any remaining pellets from the hopper and the auger feed system. Scoop out the pellets and then run the auger until the hopper is empty and pellets stop flowing (this can be done by pressing the "ON" button with the viewing door open). Vacuum out the hopper. Thoroughly clean the burn pot, and firebox. It may be desirable to spray the inside of the cleaned hopper with an aerosol silicone spray if your stove is in a high humidity area. The exhaust system should be thoroughly cleaned.

MAINTENANCE SCHEDULE

Use the following as a guide under average use conditions. Gaskets around door and door glass should be inspected and repaired or replaced when necessary.

	Daily	Weekly	Monthly or as needed
Burn Pot	Stirred	Empty	
Combustion Chamber		Brushed	
Ashes		Check	Empty
Interior Chambers			Vacuumed
Combustion Blower Blades			Vacuumed / Brushed
Convection Blower Impeller			Vacuumed / Brushed
Vent System			Cleaned
Gaskets			Inspected
Glass	Wiped	Cleaned	
Hopper (end of season)			Empty & Vacuumed

CONTROL BOARD FUNCTIONS



START-UP SEQUENCE OF EVENTS		
Once the control panel is turned on, a timer begins that will start, stop and continue operation of the heater as a preset temperature is achieved.		
COMPONENT	OPERATION START	OPERATION END
Draft Fan	Starts Immediately	Will continue until shutdown. Shutdown will occur when the operating temperature is below approx. 90 degrees.
Agitator	Begins to turn once the heater reaches operating temperature	Will continue intermediately, as determined by the "HEAT SETTING", until shutdown.
Auger	In PR-1 mode: Auger turns immediately. In CR-1: Three minutes after starting, the auger will begin to turn	The auger will continue at the feed rate specified by the "HEAT SETTING". NOTE: Safety switches, HI limit and vacuum sensor, must be activated to continue proper operation.
Room Fan	Begins to run when heater reaches operating temperature	Will continue to operate until the heater cools down to below approx. 90 degrees. This may take several hours.
Automatic Shutdown	If after 15 minutes, the heater has not reached the preset operating temperature, the unit will begin to automatically shut down.	Should the timer expire before the preset operating temperature is achieved, simply reset the heater by pressing the "ON" button.
Normal Operation	If after 15 minutes the preset operating temperature of approx. 110 degrees is achieved, normal operation will continue.	Operation will continue until either the heater's control is to the "OFF" position, or the operating temperature falls below approx. 90 degrees. At such time the heater will default to the "Automatic Shut Down".
Igniter	Starts immediately	Will continue operation for a preset time, then shut-off

SHUTDOWN SEQUENCE OF EVENTS		
Once the Heater has reached the normal operating temperature and switched to the "OFF" position, the unit will initiate a slow down, reducing the fuel rate until the heater's "LOW LIMIT SAFETY" sensor tells the control board it is safe to shutdown.		
COMPONENT	SHUTDOWN	OPERATION END
Draft Fan	Unchanged operation until preset "OFF" temperature is achieved.	Continues until the operating temperature falls below approx. 90 degrees. May take several hours.
Agitator	Rotates continuously until preset "OFF" temperature is achieved.	Continues until the operating temperature falls below approx. 90 degrees.
Auger	Slows down to a reduced fuel setting until preset "OFF" temperature is achieved.	The auger will continue at the reduced feed rates until the operating temperature falls below approx. 90 degrees. NOTE: Safety switches, HI limit and vacuum sensor, must be activated to continue proper operation.
Room Fan	Unchanged operation until preset "OFF" temperature is achieved.	Will continue to operate until the heater cools down to below approx. 90 degrees. This may take several hours.
Automatic Shutdown	If the heater's "HI LIMIT" sensor snaps open, this will cause an automatic shutdown. An error code will be displayed (Err1). NOTE: "HI LIMIT" errors are usually the result of operating at the highest heat setting for long periods of time, room fan failure or loose wire connection.	It is rare that the HI LIMIT temperature is reached. However, should this error occur, let the heater cool down for an hour then restart.

ERROR CODES & DISPLAY INDICATORS

CAUTION: WHEN PERFORMING ANY INTERNAL ELECTRICAL MAINTENANCE

- **MOVING PARTS INSIDE OF THE CABINET MAY CAUSE INJURY. DO NOT OPERATE UNIT WITH PANELS REMOVED OR OPEN.**
- **HOT PARTS. DO NOT OPERATE THE UNIT WITH PANEL OPEN.**
- **RISK OF ELECTRIC SHOCK. DISCONNECT POWER BEFORE SERVICING UNIT.**
- **IN THE EVENT OF COMPONENT FAILURE, REPLACE WITH THE ORIGINAL FACTORY EQUIPMENT.**

Error Code	Error Description	Possible Causes
Err1	The high limit temperature sensor has tripped.	Inadequate ventilation. Room fan failure. Exhaust Blockage. Electrical Open in the over temperature switch or wiring.
Err2	The low limit temperature sensor has tripped.	Hopper Empty. Auger output failure or jam. Poor flame or fuel quality caused fire to burn too slowly or go out. Electrical open in low temperature switch or wiring. Fire was not well established before the PCB's programmed time limit expired.
Err3	The heater was unable to reach the Room Fan On temperature within the startup time.	Poor flame or fuel quality caused fire to burn too slowly or go out. Auger output failure or jam Hopper empty on startup.
Err4	The power failed while the heater was hot, and when power was restored, the fire was out.	Electrical Open in low temperature switch or wiring. Power loss
Err5	The Auger output fuse has blown.	Auger motor jammed or bad.
Err6	The Agitator output fuse has blown.	Agitator motor jammed or bad.
Err7	The Draft Fan (Exhaust Fan) output fuse has blown.	Draft Fan motor jammed or bad.
Err8	The Room Fan output fuse has blown.	Room fan motor jammed or bad.
Err9	Zero Crossing Input failed	AC supply frequency out of range.
Err10	The Igniter output fuse has blown	Igniter output has shorted/blown or igniter overload.

DISPLAY INDICATORS

Several situations or events are indicated in normal operation by blinking display indicators or segments in the display:

Flashing On Indicator: This means that the heater is in the “Start Up” awaiting for the ignition procedure to complete.

Flashing Off Indicator: This indicates that the heater is in the “Shutdown” state waiting for the OFF button, or for a 15 minute period after the heater was turned off, or for the heater to cool down, or for the door to be closed.

Flashing Dash In Heat Range Display: This indicates that the heater is in the normal run mode and is ramping from the current heat range setting to the target heat range setting. Once the ramp is complete, the dash will stop flashing. For ramping from heat range 1 to 5, the default time is 12 minutes (with a 90 second ramp time).

Flashing Heat Range Value In “Heat Range” Display: For example, if the display is showing “Hr-3” and the ‘3’ is blinking, this indicates that the heater thermostat input is open and not calling for heat. While this is happening, the actual heat range value is 1 (low).

Flashing Automatic Mode Indicator: This indicates that the heater is in normal operation and is running in the automatic mode. However, either the Draft Fan or Auxiliary setting is manually configured.

Flashing Draft Fan Setting Indicator: This indicates that the heater is in normal operation and that the vacuum sensor detects a loss of pressure either because the door is open or because there is a negative pressure in the room with respect to the exhaust.

Flashing Aux Indicator: This indicates that the igniter is on during the lighting stage.

Quick (changes twice per second) Flashing Heat Range Setting Indicator: This indicates that the heater is in normal operation and that an over temperature condition exists causing the fuel to stop.

Slow (changes once per second) Flashing Heat Range Setting Indicator: This indicates that the heater is in a cutback condition in an attempt to prevent an over temperature shutdown.

FACTORY DEFAULTS

To return the control to its original factory default settings, press and hold the AUX UP and AUX DOWN buttons together for three seconds.

HOW TO ORDER REPAIR PARTS

For Parts Assistance, Call 800-750-2723 ext 5051 or Email: parts@usstove.com , or order at www.myreplacementparts.com

The information in this owner’s manual is specific to your unit. When ordering replacement parts the information in this manual will help to ensure the correct items are ordered. Before contacting customer service write down the model number and the serial number of this unit. That information can be found on the certification label attached to the back of the unit. Other information that may be needed would be the part number and part description of the item(s) in question. Part numbers and descriptions can be found in the “Repair Parts” section of this manual. Once this information has been gathered you can contact customer service by phone 1-800-750-2723 Ext 5051 or Email parts@usstove.com.

Model Information	
Model Number	
Serial Number	

- Disconnect the power supply before performing any maintenance! NOTE: Turning the heater to “OFF” does not disconnect the power to all of the electrical components of the heater.
- Never try to repair or replace any part of the heater unless instructions for doing so are given in this manual. All other work should be done by a trained technician.

PROBLEM	CAUSE: Too rich air/fuel mixture
Orange, lazy flame, excessive fuel build-up in the burnpot.	<p>Clean out the burnpot</p> <p>Make sure the cleanouts on each side of the damper are closed completely.</p> <p>Not enough combustion air. Adjust the air damper to a more open position.</p> <p>Make sure that the viewing door is closed and sealed properly. If not, adjust the door catch or replace the gasket.</p> <p>Check that all outside connections are clear of any obstructions.</p> <p>Check the exhaust system, clean as needed.</p>
PROBLEM	Cause: Burnpot out of fuel
Fire goes out or heater shuts down	<p>Hopper is empty, refill the hopper</p> <p>Loss of draft pressure. Make sure the viewing door is closed and sealed properly. Check the outside connections for any obstructions. Check the exhaust system; clean as needed.</p> <p>Check that the pressure switch connection to the firebox is free of ashes or clear of any obstructions.</p> <p>Auger system may be jammed or there is a “bridging” of fuel in the hopper preventing fuel flow into the auger feed system.</p> <p>Too much combustion air. Adjust damper to a more closed position.</p>
PROBLEM	Cause: Auto-Start Igniter fails to ignite the fuel in the burnpot.
Heater does not start a fire when the “ON” button is pressed.	<p>Check the pellets quality. If moist or damp, replace with dryer fuel.</p> <p>Check that the auto-start igniter port is not blocked with ash or soot. (The igniter is located behind the burnpot.)</p> <p>The auto-start igniter should glow on start-up. If you can not visible see the igniter glowing, then it may need to be replaced or there is a problem with the electrical system. Check wiring.</p> <p>Loss of draft pressure. Make sure the viewing door is closed and sealed properly. Check the outside connections for any obstructions. Check the exhaust system; clean as needed.</p>
PROBLEM	Cause: Not enough combustion air or fuel has too much moisture.
Viewing glass becomes black shortly after start-up.	<p>Adjust the air damper to a more open position.</p> <p>Use a fuel with less moisture content.</p>
PROBLEM	Cause: Not enough combustion air or fuel has too much moisture.

WIRING DIAGRAM

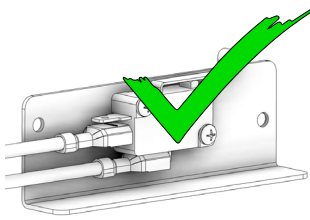
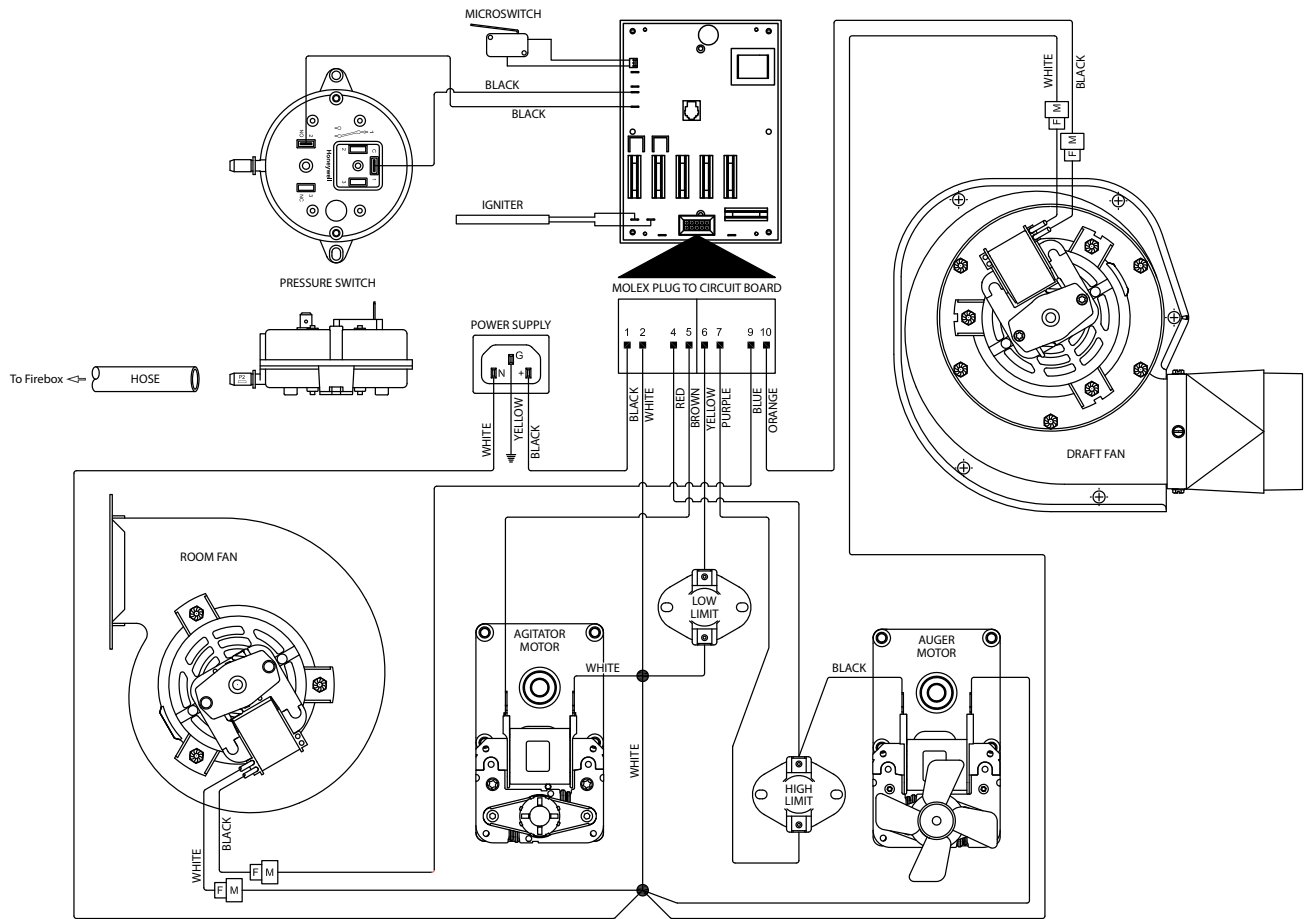

CORRECT

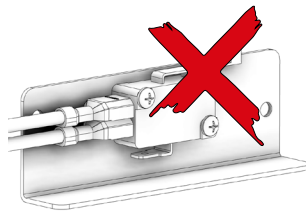

WRONG

Ensure the wires are connected to the bottom two prongs of the hopper switch as shown.

WIRING SCHEMATIC

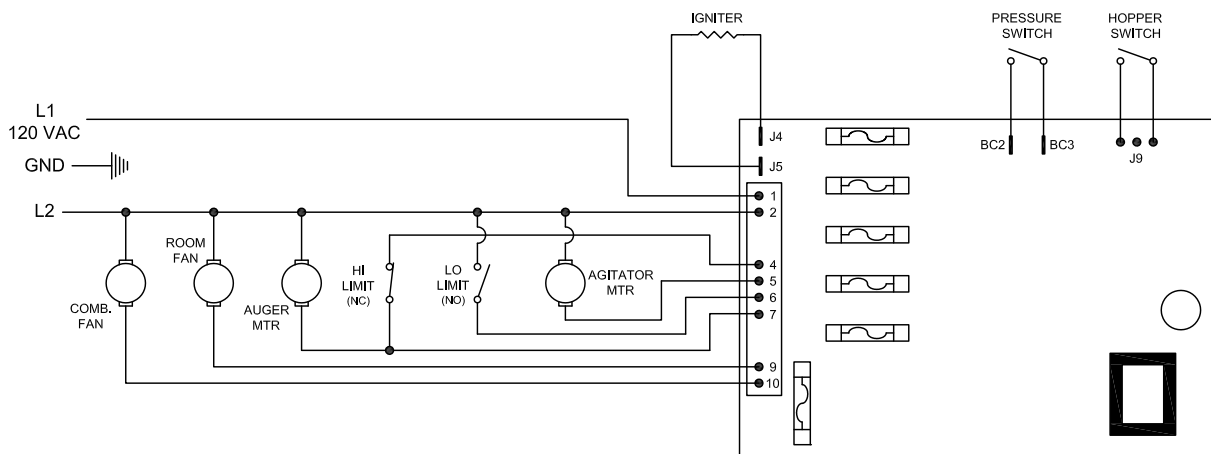

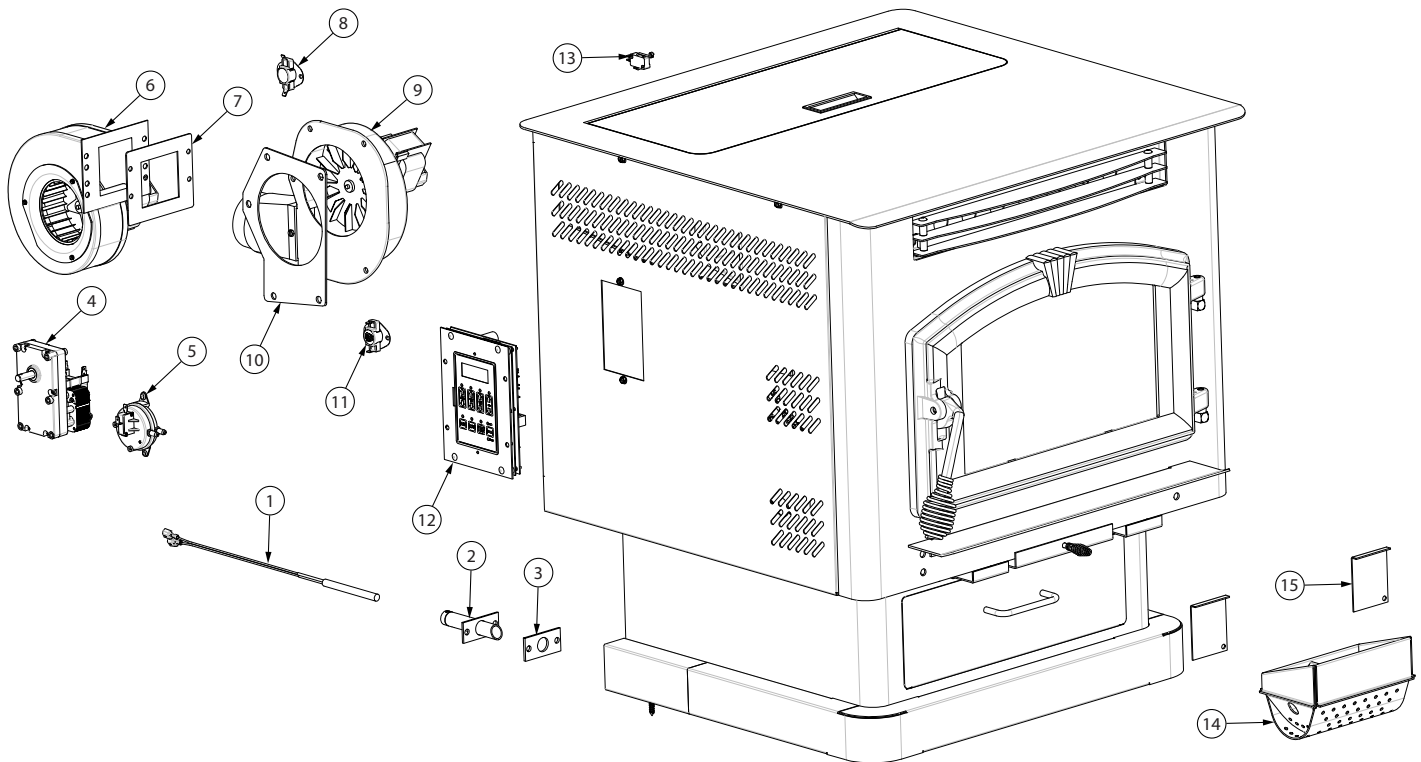

Key	Part #	Description	Qty
1	80543	Igniter Cartridge	1
2	69593	Igniter Tube Weldment	1
3	88118	Igniter Flange Gasket	1
4	80456	Drive Motor (Agitator)	1
5	80549	Pressure Switch	1
6	80472	Distribution Blower	1
7	88106	Distribution Blower Gasket	1
8	80381	110°F Snap Disc (Low Limit)	1
9	80473	Exhaust Blower	1
10	88100	Exhaust Blower Gasket	1
11	80390	170°F Snap Disc (High Limit)	1
12	80575	PCB, Circuit Board	1
13	80491	Micro Switch	1
14	891660	Burnpot	1
15	25524	Ash Cleanout (Inner)	2

To order parts:

Call 1-800-750-2723 Ext 5051 or

Email to: parts@usstove.com

IN ORDER TO MAINTAIN WARRANTY, COMPONENTS MUST BE REPLACED USING ORIGINAL MANUFACTURERS PARTS PURCHASED THROUGH YOUR DEALER OR DIRECTLY FROM THE APPLIANCE MANUFACTURER. USE OF THIRD PARTY COMPONENTS WILL VOID THE WARRANTY.

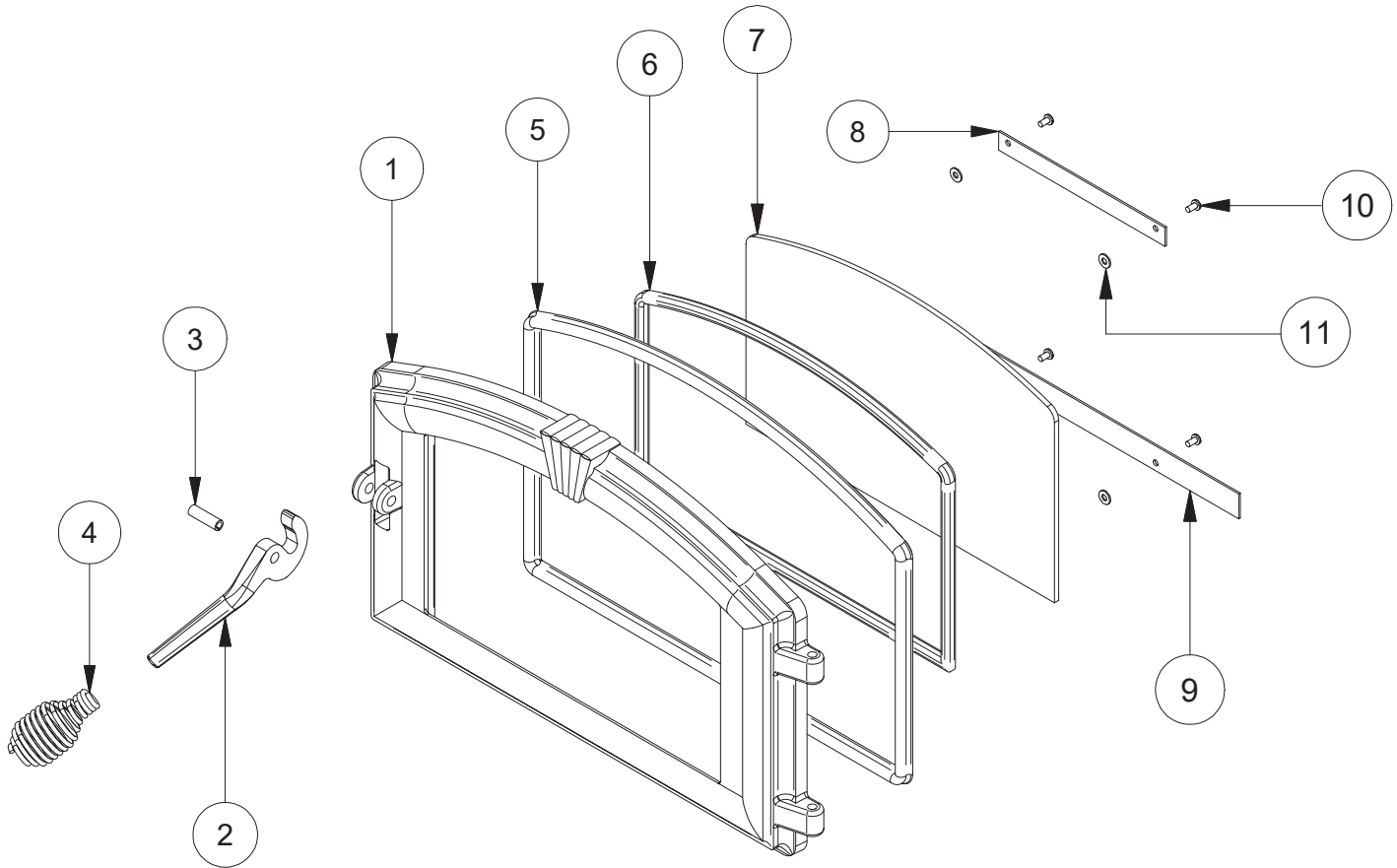

Key	Part #	Description	Qty
1	25491	Feed Door	1
2	25492	Handle, Door	1
3	83506	Roll Pin, 3/8 x 1-1/4	1
4	891135	Handle, Spring (Parts Bag)	1
5	88112	Gasket, 1/2" Sq. Rope	5 ft
6	88087	Gasket, Glass (1 x 3/16)	4 ft
7	891131	Glass Ceramic	1
8	25464	Retainer, Top Glass	1
9	25465	Retainer, Bottom Glass	1
10	83202	Machine Screw	4
11	83278	#10 Flat Washer	4

To order parts:

Call 1-800-750-2723 Ext 5051 or

Email to: parts@usstove.com

IN ORDER TO MAINTAIN WARRANTY, COMPONENTS MUST BE REPLACED USING ORIGINAL MANUFACTURERS PARTS PURCHASED THROUGH YOUR DEALER OR DIRECTLY FROM THE APPLIANCE MANUFACTURER. USE OF THIRD PARTY COMPONENTS WILL VOID THE WARRANTY.



SERVICE RECORD

It is recommended that your heating system is serviced regularly and that the appropriate Service Interval Record is completed.

SERVICE PROVIDER

Before completing the appropriate Service Record below, please ensure you have carried out the service as described in the manufacturer's instructions. Always use the manufacturer's specified spare part when replacement is necessary.

Service 01 Date: _____

Engineer Name: _____

License No.: _____

Company: _____

Telephone No.: _____

Stove Inspected: Chimney Swept:

Items Replaced: _____

Service 02 Date: _____

Engineer Name: _____

License No.: _____

Company: _____

Telephone No.: _____

Stove Inspected: Chimney Swept:

Items Replaced: _____

Service 03 Date: _____

Engineer Name: _____

License No.: _____

Company: _____

Telephone No.: _____

Stove Inspected: Chimney Swept:

Items Replaced: _____

Service 04 Date: _____

Engineer Name: _____

License No.: _____

Company: _____

Telephone No.: _____

Stove Inspected: Chimney Swept:

Items Replaced: _____

Service 05 Date: _____

Engineer Name: _____

License No.: _____

Company: _____

Telephone No.: _____

Stove Inspected: Chimney Swept:

Items Replaced: _____

Service 06 Date: _____

Engineer Name: _____

License No.: _____

Company: _____

Telephone No.: _____

Stove Inspected: Chimney Swept:

Items Replaced: _____

Service 07 Date: _____

Engineer Name: _____

License No.: _____

Company: _____

Telephone No.: _____

Stove Inspected: Chimney Swept:

Items Replaced: _____

Service 08 Date: _____

Engineer Name: _____

License No.: _____

Company: _____

Telephone No.: _____

Stove Inspected: Chimney Swept:

Items Replaced: _____